

**OFFICE OF THE PRINCIPAL**

COLLEGE OF ARTS &amp; CRAFTS

PATNA UNIVERSITY, PATNA

**NOTICE INVITING QUOTATION**

NIQ No.: 02/2016-17

Date:08/12/2016

Designation of officer inviting quotation	Principal, College of Arts & Crafts, Patna
Place, Time & Date of receiving of Quotation	Office of the Principal, College of Arts & Crafts, Patna upto 3:00 pm on 17/12/2016
Place, Time & Date of opening Tender	Office of the Principal, College of Arts & Crafts, Patna at 3:30 pm on 17/12/2016

**PART-1 SUPPLYING OF COMPUTER WITH THEIR ALLIED UNITS**

Sealed quotations are invited in four parts separately from manufacturers or their authorized dealers for supplying the following items :

Sr. No.	Name of Items	Company Make	Quantity
1	Desktop Computer with i7 processor, 6 <sup>th</sup> generation, 8 GB RAM, 2GB Graphic Card 1TB Internal HDD, Monitor-19.5" ITS display with 178/178 viewing angle with 800 VA UPS	Dell/HP/HCL/LENOVO	21 nos
2	Workstation (Computer) Xeon Processor as per attached specification	Dell/HP/HCL /LENOVO	1 nos
3	10 KVA UPS single phase to Single Phase 240 V DC with 20 Batteries of 28AH (maintenance free) with Battery Stand	Microtech/Luminous	1 nos
4	Antivirus for 30 users for one year subscription	Quick Heal or similar	1 nos

**PART-2 SUPPLYING OF OFFICE FURNITURES**

Sr. No.	Name of Items	Company Make	Quantity
1	Lateral Filing Cabinet 04 Draw with Metal top size 1323Hx900Wx450D	Godrej/Methodex or similar	10 nos
2	Office Table Versatila V4 (Bembrace)	Godrej/Methodex or similar	1 nos
3	Storewel Plain 4 Sh	Godrej/Methodex or similar	15 nos
4	Steel Rack Size: 72"x36"x15"	Godrej/Methodex or similar	10 nos
5	4 Door Book Case	Godrej/Methodex or similar	10 nos
6	Revolving Chair (PCH 7001)	Godrej/Methodex or similar	10 nos

**PART-3 SUPPLYING OF ART FURNITURES**

Sr. No.	Name of Items	Make	Quantity
1	Painting Easel As per attached drawing& specification	SSI/NSIC REGISTERED FIRM	25 nos
2	Model Study table As per attached drawing& specification	SSI/NSIC REGISTERED FIRM	4 nos
3	Stool As per attached drawing& specification	SSI/NSIC REGISTERED FIRM	200 nos
4	Height adjustable Table As per attached drawing& specification	SSI/NSIC REGISTERED FIRM	100 nos

**PART-4 SUPPLYING OF MACHINARIES**

Sr. No.	Name of Items	Make	Quantity
1	Etching press 36*72(Inch)	Reputed Brand	1 nos
2	Etching Manual Press 40*80(Inch)	Reputed Brand	1 nos
3	Rubber Roller 13*22 (Inch)	Reputed Brand	1 nos
4	Felt Set for Etching Press	Reputed Brand	1 nos
5	Metal Sheet Cutter	Reputed Brand	1 nos
6	Fiber Tray 24*48	Reputed Brand	1 nos
7	Rubber Roller 3*12 (Set of 3)	Reputed Brand	1 nos
8	Rubber Roller 5*15 (Set of 3)	Reputed Brand	1 nos
9	Rubber Roller 6*18 (Set of 3)	Reputed Brand	1 nos
10	N Bajat Air Cooled Welding Machine 250 AMP	Reputed Brand	1 nos

11	Welding Cable(a) 500 wire	Reputed Brand	1 nos
12	(b) 700 wire	Reputed Brand	1 nos
13	(c) 1000 wire	Reputed Brand	1 nos
14	Welding Holder	Reputed Brand	2nos
15	Welding hand Screen set	Reputed Brand	2 nos
16	Electrode	Reputed Brand	1 Pkt

**PART-5 SUPPLYING OF DIGITAL CAMERA AND THEIR ACCESSORIES**

Sr. No.	Name of Items	Company Make	Quantity
1	DSLR Digital Camera	Nikon/Canon or similar	1 nos
2	Flash SB5000	Nikon/Canon or similar	1 nos
3	Lens	Nikon/Canon or similar	1 nos

**TERMS & CONDITIONS:**

1. Paper submitted with quotation:
  - (i) TIN/VAT/ PAN
  - (ii) Authorized Dealership Certificate from manufacturing company
  - (iii) Catalog/Broacher of the product.
2. Payment – 100% Against Supply
3. Validity of offer: 60 Days
4. The Bidder should inspect the site before filling in and submitting the quotation to get fully acquainted with the scope of work as no claim whatsoever will be entertained for any alleged ignorance thereof. Quotations must be submitted in original and without making any additions, alternations, and as per details given in other clauses given hereunder. The requisite details shall be filled in by the Bidder in the quotation Document wherever required.
5. Quotations must be submitted in original and without making any additions, alternations, and as per details given in other clauses given hereunder. The requisite details shall be filled in by the Bidder in the quotation Document wherever required.
6. The agency should have experience of similar type of work at any Govtt organization or Universities.
7. The sealed quotation should also be sent through courier/Registered/Speed Post. Conditional quotation or quotations received after the due time and date shall not be entertained in any circumstances. College Authority would not be responsible for any delay or loss of the quotation document, The quotations will be opened in the office of the undersigned in presence of any intending supplier or his/her authorized representative who may wish to be present at the designated time and place. If the fixed date turns out to be the holiday, the date of opening will be the next day.
8. Earnest money is to be deposited in the shape of D.D./ Banker's cheque in favour of The Principal, College of Arts & Crafts, Patna University, Patna @ 2% of quoted amount. For claiming exemption from depositing earnest money, the quotationer should be registered with NSIC or DGS&D specifically for the store with specification as mentioned in quotation schedule.
9. At the time of opening of Quotation only participant quotationer or his single authorized representative with authority letter will be allowed to present.
10. The EMD shall be forfeited If the bidder withdraws his bid during the period of bid validity.
11. All disputes, what so ever shall be referred to the sole arbitration of The Principal, College of Arts & Crafts, Patna University, Patna and his decision shall be final and binding on the agency.

12. Bidders should submit details in the format given at Annexure-A and should quote the rates in the format given at Annexure-B as per Specification of Annexure-C. Incomplete bids will summarily be rejected. All corrections and alterations in the entries of quotation document will be signed in full by the Bidder with date. No erasing or over- writings are permissible.
13. The undersigned reserve the right to accept or reject any or all the quotation without assigning any reasons.
14. All the matters subject to the jurisdiction of Patna High Court.

Principal  
College of Arts & Crafts  
Patna University, Patna

**FOR PART-1**

(To be submitted on Letter Head of the Agency)

**Annexure- A**

**BID DOCUMENT**

Bid should indicate following information along with the self-attested photocopies of supporting documents:

Detail of Earnest Money: Rs..... DD No....., Date & Name of Bank.....
--

1. THE FIRM

a) Name \_\_\_\_\_

b) Regd. Address \_\_\_\_\_

c) Address of Office at Patna \_\_\_\_\_

d) Contact Person's

i) Name & Design. \_\_\_\_\_

ii) Address \_\_\_\_\_

iii) Tel No. Landline \_\_\_\_\_ Mobile \_\_\_\_\_

iv) Email ID \_\_\_\_\_

2. Type of Firm : \_\_\_\_\_ enclosed. (Pl. specify)

{Proprietorship/ Private Ltd./PublicLtd./ Cooperative/ NGO/PSU (Please tick and enclose copy of Memorandum/ Articles of Association/ Certificate of Incorporation)}

3. PAN/GIR No. : \_\_\_\_\_  
(Please enclose photocopy)

4. TIN No. : \_\_\_\_\_  
(Please enclose photocopy)

5. Experience of similar work in the field during the last three years(pl. specify) : Rs.\_\_\_\_\_.  
(Should have completed similar type of work in reputed organizations including at least one PSU/Govt. Deptt./Institution with work order not less 50% of quoted amount.  
[Please submit copies of documentary evidence i.e. work order].

**Signatures of authorized person**

**Name** .....

**Designation**.....

**Seal**

**FOR PART-1**

(To be submitted on Letter Head of the Agency)

**Annexure-B**

**PRICE BID**

**PART-1 SUPPLYING OF COMPUTER WITH THEIR ALLIED UNITS**

Sr. No.	Name of Items	Company Make	Quantity	Rate	Unit	Amount
1	Desktop Computer with i7 processor, 6 <sup>th</sup> generation, 8 GB RAM, 2GB Graphic Card 1TB Internal HDD, Monitor-19.5" ITS display with 178/178 viewing angle with 800 VA UPS		21 nos		Each	
2	Workstation (Computer) Xeon Processor as per attached specification		2 nos		Each	
3	UPS single phase to Single Phase 240 V DC with 20 Batteries of 28AH with Battery Stand		2 nos		Each	
4	Antivirus for 30 users for one year subscription		1 nos		Each	
Total Amount in Rs. in figure						
Total Amount in Rs. in Word:						

**Note:-**

1. Delivery Period : 15 Days
2. Rate should be Inclusive all taxes, installation, Packing & Transportation charge to College of Arts and Crafts, P.U, Patna.
3. The break-up of amount quoted in respect of VAT/ED etc. should be attached in a separate sheet.
4. The agency should have clearly mention the warranty of products quoted by them.

**Signatures of authorized person**

**Name .....**

**Designation.....**

**Seal**

**FOR PART-1**  
**Annexure-C**  
**Workstation (Computer)**

S No	System Component	Description
1	Processor	E3-1220 v5 ( 3.0GHz / 4C / 8M / 2133 / 80W / Turbo / GT0 )
2	Motherboard & Chipset	C Series Chipset
3	Memory (capacity & no of DIMM slots used)	8GB DDR-3 1600 MHz/ 4 DIMM Slots and Expandable upto 64 GB RAM
4	Hard Disk	4 TB, SATA III, 6 gbps 7200 rpm
5	Graphic Card	4 GB Graphics Card Quadro
6	Sound Controller	Integrated sound controller
7	Network Controller	Integrated Gigabit Ethernet controller
8	Optical Drive	DVD RW
9	PCI Slots	4 PCI e Slots
10	Ports	1x serial port, 4 x USB 2.0 or higher ports (2 ports on front), 1xKeyboard port, 1xMouse port, 1xRJ45 LAN, Display port, VGA port
11	Media Card Reader	29 in 1 Media Card Reader
12	Display (W/WO inbuilt speakers)	22" TFT LCD Dual Monitor
13	Keyboard & Mouse	104 Keys OEM Keyboard and OEM Optical Scroll Mouse with Mouse pad
14	Speaker and Headphones with Mic	Yes
15	SMPS	100-127 volt,50-60 Hz, input 200-240,
16	Chasis	Energy star 5.0 complaint
17	OS	Windows 10 Pro

**TECHNICAL SPECIFICATIONS FOR 10 KVA UPS**

Capacity	10 Kva = 10 KW
Technology	Digital signal processor controlled True Online,
	High Frequency
Inverter Technology	PWM technology with IGBTs with built In galvanic isolation
Noise Level	Less than 50 dB
Operating Temperature	0-45 degree centigrade
Humidity	10 to 95% no-condensing
Harmonic Distortion	≤2% (linear load)
	≤5% (non-linear load)
Total DC bus voltage	240 VDC
Battery recharge time	
(After Complete discharge)	8 Hours
to 100% charge	
Crest Factor	Minimum 3:1 at full load
Out put Wave Form	Pure Sine wave
Cold Start feature	Required
<b>INPUT</b>	
Input	Three phase 4 wire
Input Voltage Range	415VAC+ Neutral +earth
Input Frequency Range	46-54Hz
Line low/High Cutoff	330 VAC to 478 VAC
Power Factor	>0.9
<b>OUTPUT</b>	
Output Voltage	220/230 VAC programmable1 phase+N
Output Frequency	50hz +/- 0.5%(Free running)
<b>EFFICIENCY</b>	
AC to AC	93%

DC to AC	94%
<b>STATIC SWITCH</b>	Should take care of 100% load transfer
(Bi-directional) for all ratings	without break
<b>LOAD POWER FACTOR</b>	0.9% lag to unit
<b>OVERLOAD CAPACITY</b>	125 % for 10 mts
<b>UPS SHUT DOWN</b>	UPS shut down with alarm and Indication in case of Out put over voltage Output under voltage Battery Low Inverter over load over temperature Output short
<b>ISOLATION</b>	
Isolation of power	Both input & Output have MCB's. Also battery connection have MCB/MCCB/ switch
Isolation Transformer	At input
Galvanic Isolation	Required
Manual Service Bypass	Automatic Static bypass
<b>PROTECTION</b>	
Short Circuit Protection	MCB / MCCB Trips and UPS shut down with out Blowing any fuses
Input over and under voltage	MCB with alarm. UPS safe in the case of hight Voltage/High Current/ high spike/ high surges at input to the UPS
Output over & under voltage	MCB with alarm. The load conneted to the UPS should be protected under any circumstance
<b>INDICATORS</b>	
	Mains on
	Inverter On
	Mains high
	mains low
	Inverter over voltage
	Inverter under voltage
	Battery Low
	Battery Over charge
	Inverter overload/Current
	Over temperature
<b>LCD DISPLAY</b>	Input/Output voltage
	Out put frequency
	Load current
	Battery voltage
<b>DEGREE OF PROTECTION</b>	IP 20
<b>COMMUNICATION</b>	
<b>INTERFACE</b>	RS 232 port for auto shut down, SNMP
<b>AUDIBLE ALARM</b>	
	Battery low
	Mains failure
	Out put over current
	Overload
<b>BATTERY</b>	100 AH Poly Propylene Tubular battery-20 Nos
<b>QUALITY STANDARDS</b>	
<b>UPS</b>	ISO 9001:2008
<b>BATTERY</b>	ISO 14001
<b>BATTERY STAND</b>	Required

**(b) Batteries of 28 AH**

Capacity:	28 AH
Battery Type:	SMF Battery
Color:	Black
Voltage:	12 V
Weight:	8.1 KG(s)
Warranty:	24 Month(s)or above

**(C) Battery Stand**

As per supplied Items of Batteries.



**FOR PART-2**

(To be submitted on Letter Head of the Agency)

**Annexure- A**

**BID DOCUMENT**

Bid should indicate following information along with the self-attested photocopies of supporting documents:

Detail of Earnest Money: Rs..... DD No....., Date & Name of Bank.....
--

1. THE FIRM

a) Name \_\_\_\_\_

b) Regd. Address \_\_\_\_\_

c) Address of Office at Patna \_\_\_\_\_

d) Contact Person's

i) Name & Design. \_\_\_\_\_

ii) Address \_\_\_\_\_

iii) Tel No. Landline \_\_\_\_\_ Mobile \_\_\_\_\_

iv) Email ID \_\_\_\_\_

2. Type of Firm : \_\_\_\_\_ enclosed. (Pl. specify)  
{Proprietorship/ Private Ltd./PublicLtd./ Cooperative/ NGO/PSU (Please tick and enclose copy of Memorandum/ Articles of Association/ Certificate of Incorporation)}

3. PAN/GIR No. : \_\_\_\_\_  
(Please enclose photocopy)

4. TIN No. : \_\_\_\_\_  
(Please enclose photocopy)

5. Experience of similar work in the field during the last five years(pl. specify) : Rs.\_\_\_\_\_  
(Should have completed similar type of work in reputed organizations including at least one PSU/Govt. Deptt./Institution with work order not less than (i) Rs. 10.00 lakh/p.a. in a single order; or (ii) Rs. 15.00 lakh/p.a. in two orders ; or (iii) Rs. 20.00 lakh/p.a. in three orders)  
[Please submit copies of documentary evidence e.g. work order, corresponding satisfactory job completion certificates from clients specifying value and period of work order

**Signatures of authorized person**

**Name** .....

**Designation**.....

**Seal**

**FOR PART-2**

(To be submitted on Letter Head of the Agency)

**Annexure-B**

**PRICE BID**

**(1) SUPPLYING OF FURNITURES**

Sr. No.	Name of Items	Company Make	Quantity	Rate	Unit	Amount
1	Lateral Filing Cabinet 04 Draw with Metal top size 1323Hx900Wx450D		10 nos		Each	
2	Office Table Versatila V4 (Bembrance)		1 nos		Each	
3	Storwel Plain 4 Sh		15 nos		Each	
4	Steel Rack Size: 72"x36"x15"		10 nos		Each	
5	4 Door Book Case		10 nos		Each	
6	Revolving Chair (PCH 7001)		10 nos		Each	
Total Amount in Rs. in figure						
Total Amount in Rs. in Word:						

**Note:-**

- 1. Delivery Period : 15 Days**
- 2. Rate should be Inclusive all taxes, installation, Packing & Transportation charge to College of Arts and Crafts, P.U, Patna.**
- 3. The break-up of amount quoted in respect of VAT/ED etc. should be attached in a separate sheet.**
- 4. The agency should have clearly mention the warranty of products quoted by them.**

**Signatures of authorized person**

**Name .....**

**Designation.....**

**Seal**

**FOR PART-3**

(To be submitted on Letter Head of the Agency)

**Annexure- A**

**BID DOCUMENT**

Bid should indicate following information along with the self-attested photocopies of supporting documents:

Detail of Earnest Money: Rs..... DD No....., Date & Name of Bank.....
--

1. THE FIRM

a) Name \_\_\_\_\_

b) Regd. Address \_\_\_\_\_

c) Address of Office at Patna \_\_\_\_\_

d) Contact Person's

i) Name & Design. \_\_\_\_\_

ii) Address \_\_\_\_\_

iii) Tel No. Landline \_\_\_\_\_ Mobile \_\_\_\_\_

iv) Email ID \_\_\_\_\_

2. Type of Firm : \_\_\_\_\_ enclosed. (Pl. specify)  
{Proprietorship/ Private Ltd./PublicLtd./ Cooperative/ NGO/PSU (Please tick and enclose copy of Memorandum/ Articles of Association/ Certificate of Incorporation)}

3. PAN/GIR No. : \_\_\_\_\_  
(Please enclose photocopy)

4. TIN No. : \_\_\_\_\_  
(Please enclose photocopy)

5. Experience of similar work in the field during the last three years(pl. specify) : Rs.\_\_\_\_\_.  
(Should have completed similar type of work in reputed organizations including at least one PSU/Govt. Deptt./Institution with work order not less 50% of quoted amount.  
[Please submit copies of documentary evidence i.e. work order].

**Signatures of authorized person**

**Name** .....

**Designation**.....

**Seal**

**FOR PART-3**

(To be submitted on Letter Head of the Agency)

**Annexure-B**

**PRICE BID**

**SUPPLYING OF ART FURNITURES**

<b>Sr. No.</b>	<b>Name of Items</b>	<b>Company Make</b>	<b>Quantity</b>	<b>Rate</b>	<b>Unit</b>	<b>Amount</b>
1	Painting Easel		25 nos		Each	
2	Model Study table		4 nos		Each	
3	Stool		200 nos		Each	
4	Height adjustable Table		100 nos		Each	
Total Amount in Rs. in figure						
Total Amount in Rs. in Word:						

**Note:-**

- 1. Delivery Period : 30 Days**
- 2. Rate should be Inclusive all taxes, installation, Packing & Transportation charge to College of Arts and Crafts, P.U, Patna.**
- 3. The break-up of amount quoted in respect of VAT/ED etc. should be attached in a separate sheet.**
- 4. The agency should have clearly mention the warranty of products quoted by them.**

**Signatures of authorized person**

**Name .....**

**Designation.....**

**Seal**

**FOR PART-3**  
**Annexure-C**

1. Painting Easel

# Painting Easel

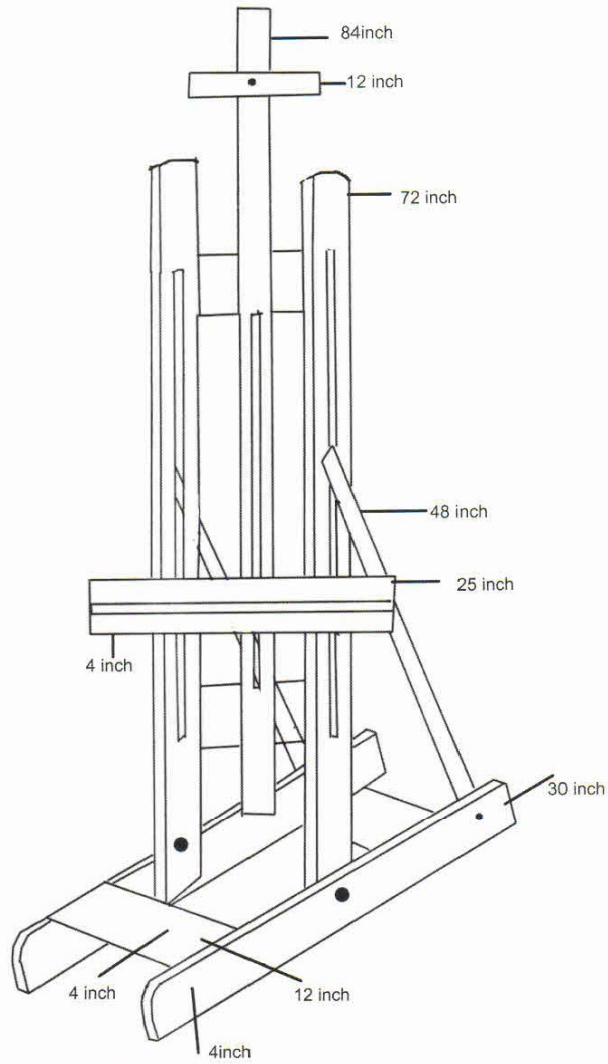

## Specifcation

- 1 wood sisham
- 2 Iron kill
- 3 Steel Bolt
- 3 Transparent polish

2

## Modal Table

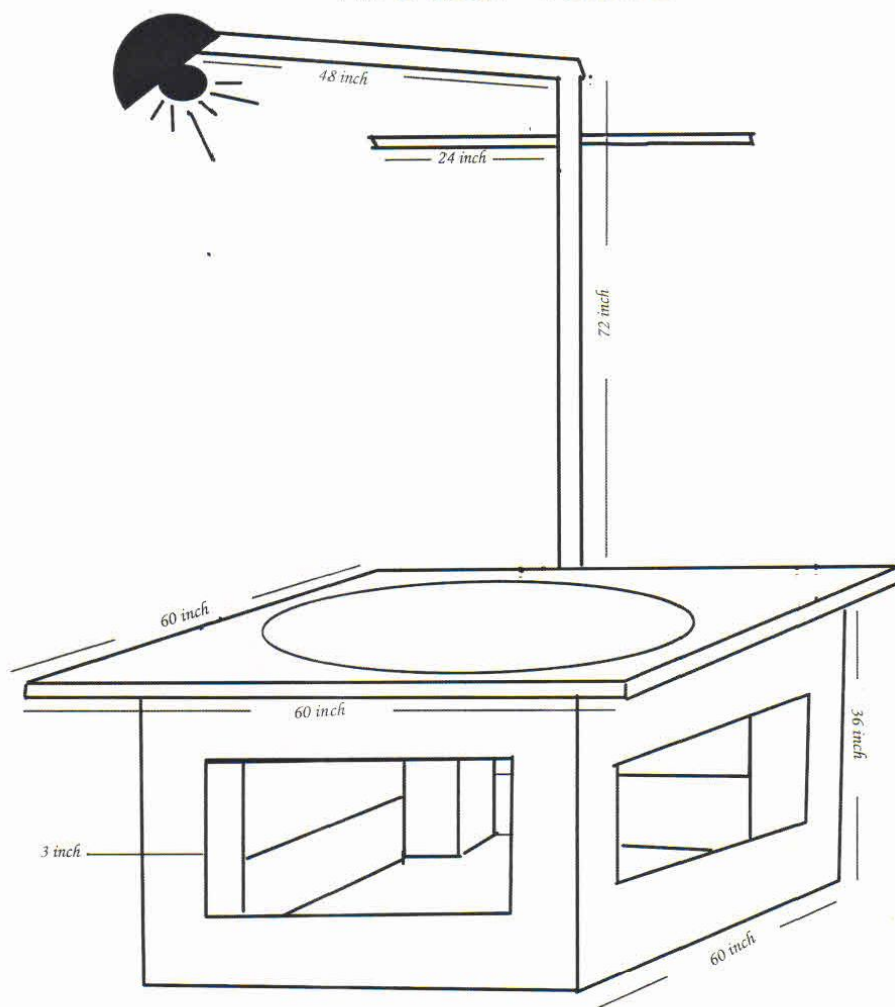

### Specifcation

- 1 wood sisham
- 2 Iron kill
- 3 Senter Whell ,Aluminium
- 4 Iron rod + Bairing
- 5 Iron Pipe
- 6 Transparent polish

### 3. Stool

3

## Stool

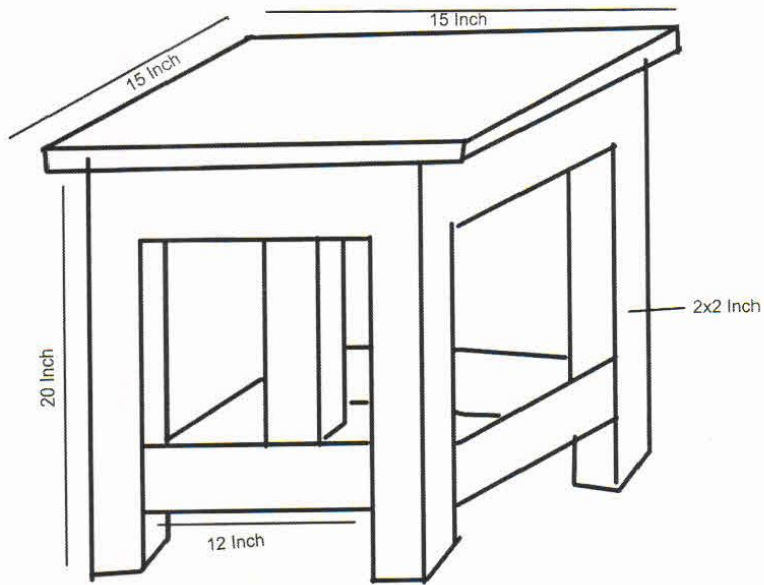

### Specifcation

- 1 wood sisham
- 2 Iron kill
- 3 Transparent polish

## Hight adjustable table

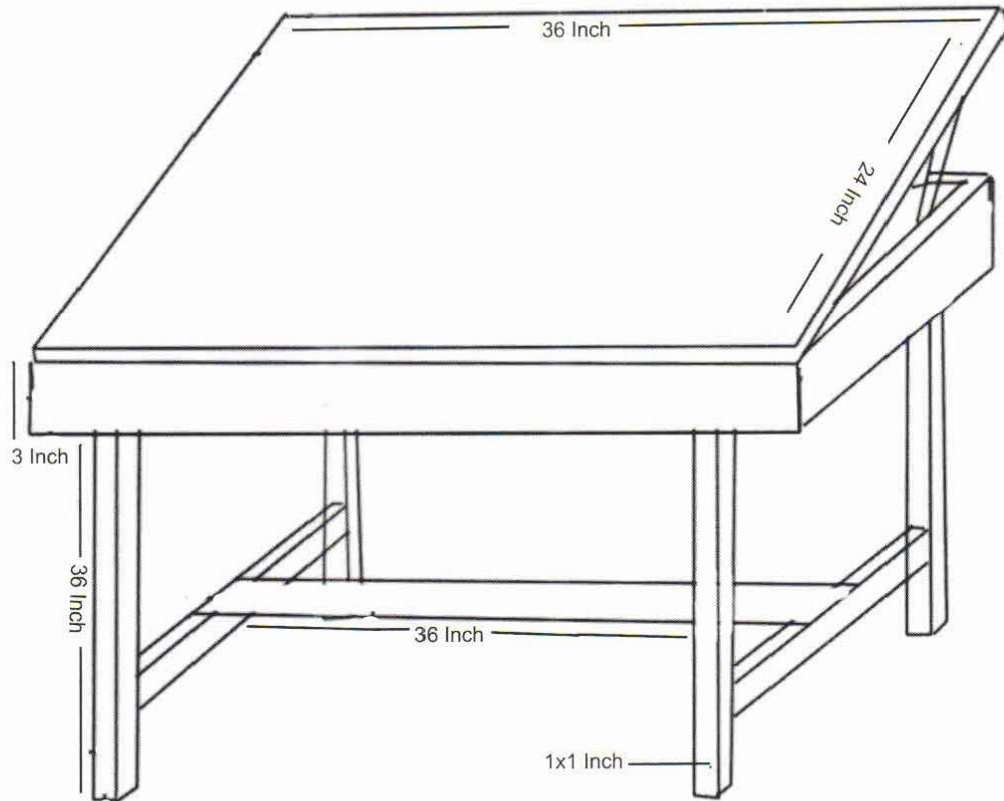

### Specifcation

- 1 wood Gamhar Bord pin putt
- 2 Iron kill
- 3 Iron Square pipe 1x4
- 4 Iron Bite 3 Inch
- 5 Dark brown color



**FOR PART-4**

(To be submitted on Letter Head of the Agency)

**Annexure- A**

**BID DOCUMENT**

Bid should indicate following information along with the self-attested photocopies of supporting documents:

Detail of Earnest Money: Rs..... DD No....., Date & Name of Bank.....
--

1. THE FIRM

a) Name \_\_\_\_\_

b) Regd. Address \_\_\_\_\_

c) Address of Office at Patna \_\_\_\_\_

d) Contact Person's

i) Name & Design. \_\_\_\_\_

ii) Address \_\_\_\_\_

iii) Tel No. Landline \_\_\_\_\_ Mobile \_\_\_\_\_

iv) Email ID \_\_\_\_\_

2. Type of Firm : \_\_\_\_\_ enclosed. (Pl. specify)

{Proprietorship/ Private Ltd./PublicLtd./ Cooperative/ NGO/PSU (Please tick and enclose copy of Memorandum/ Articles of Association/ Certificate of Incorporation)}

3. PAN/GIR No. : \_\_\_\_\_  
(Please enclose photocopy)

4. TIN No. : \_\_\_\_\_  
(Please enclose photocopy)

5. Experience of similar work in the field during the last three years(pl. specify) : Rs.\_\_\_\_\_.  
(Should have completed similar type of work in reputed organizations including at least one PSU/Govt. Deptt./Institution with work order not less 50% of quoted amount.  
[Please submit copies of documentary evidence i.e. work order].

**Signatures of authorized person**

**Name** .....

**Designation**.....

**Seal**

**FOR PART-4**

(To be submitted on Letter Head of the Agency)

**Annexure-B**

**PRICE BID**

**PART-4 SUPPLYING OF MACHINARIES**

Sr. No.	Name of Items	Company Make	Quantity	Rate	Unit	Amount
1	Etching press 36*72(Inch)		1 nos		Each	
2	Etching Manual Press 40*80(Inch)		1 nos		Each	
3	Rubber Roller 13*22 (Inch)		1 nos		Each	
4	Felt Set for Etching Press		1 nos		Each	
5	Metal Sheet Cutter		1 nos		Each	
6	Fiber Tray 24*48		1 nos		Each	
7	Rubber Roller 3*12 (Set of 3)		1 nos		Each	
8	Rubber Roller 5*15 (Set of 3)		1 nos		Each	
9	Rubber Roller 6*18 (Set of 3)		1 nos		Each	
10	N Bajat Air Cooled Welding Macnine 250 AMP		1 nos		Each	
11	Welding Cable(a) 500 wire		1 nos		Each	
12	(b) 700 wire		1 nos		Each	
13	(c) 1000 wire		1 nos		Each	
14	Welding Holder		2nos		Each	
15	Welding hand Screen set		2 nos		Each	
16	Electrode		1 pkt		Each	
Total Amount in Rs. in figure						
Total Amount in Rs. in Word:						

**Note:-**

- 1. Delivery Period : 15 Days**
- 2. Rate should be Inclusive all taxes, installation, Packing & Transportation charge to College of Arts and Crafts, P.U, Patna.**
- 3. The break-up of amount quoted in respect of VAT/ED etc. should be attached in a separate sheet.**
- 4. The agency should have clearly mention the warranty of products quoted by them.**

**Signatures of authorized person**

**Name .....**

**Designation.....**

**Seal**

**FOR PART-4**  
**Annexure-C**

**1. Air Cooled Welding Machine**

TECHNICAL SPECIFICATIONS	UNIT	CHAMP 160	CHAMP 200
Supply voltage	Volt	240, +10%, -15%	240, +10%, -15%
Phase	No	1	1
Input KVA @100% Duty cycle	KVA	4	5
Open circuit voltage @ 240 Vac	Volt	68 +/-3	68 +/-3
Welding current range	Amp	10-160	10-200
Welding current @ 60% Duty cycle	Amp	130	150
Welding current @ 100% Duty cycle	Amp	90	120
Type of cooling	Type	Forced Air	Forced Air
Class of insulation	Class	F	F
Dimensions (LxWxH)	mm	375x145x290	415x155x300
Weight (approx.)	Kg	6	7

**FOR PART-5**

(To be submitted on Letter Head of the Agency)

**Annexure- A**

**BID DOCUMENT**

Bid should indicate following information along with the self-attested photocopies of supporting documents:

Detail of Earnest Money: Rs..... DD No....., Date & Name of Bank.....
--

1. THE FIRM

a) Name \_\_\_\_\_

b) Regd. Address \_\_\_\_\_

c) Address of Office at Patna \_\_\_\_\_

d) Contact Person's

i) Name & Design. \_\_\_\_\_

ii) Address \_\_\_\_\_

iii) Tel No. Landline \_\_\_\_\_ Mobile \_\_\_\_\_

iv) Email ID \_\_\_\_\_

2. Type of Firm : \_\_\_\_\_ enclosed. (Pl. specify)  
{Proprietorship/ Private Ltd./PublicLtd./ Cooperative/ NGO/PSU (Please tick and enclose copy of Memorandum/ Articles of Association/ Certificate of Incorporation)}

3. PAN/GIR No. : \_\_\_\_\_  
(Please enclose photocopy)

4. TIN No. : \_\_\_\_\_  
(Please enclose photocopy)

5. Experience of similar work in the field during the last three years(pl. specify) : Rs.\_\_\_\_\_  
(Should have completed similar type of work in reputed organizations including at least one PSU/Govt. Deptt./Institution with work order not less 50% of quoted amount.  
[Please submit copies of documentary evidence i.e. work order].

**Signatures of authorized person**

**Name** .....

**Designation**.....

**Seal**

**FOR PART-5**

*(To be submitted on Letter Head of the Agency)*

**Annexure-B**

**PRICE BID**

**PART-5 SUPPLYING OF DIGITAL CAMERA AND THEIR ACCESSORIES**

Sealed quotations are invited from authorized dealer of Nikon/Honeywell for the supplying of following:

Sr. No.	Name of Items	Company Make	Quantity	Rate	Unit	Amount
1	DSLR Digital Camera		1 nos			
2	Flash SB5000		1 nos			
3	Lens		1 nos			
Total Amount in Rs. in figure						
Total Amount in Rs. in Word:						

**Note:-**

- 1. Delivery Period : 15 Days**
- 2. Rate should be Inclusive all taxes, installation, Packing & Transportation charge to College of Arts and Crafts, P.U, Patna.**
- 3. The break-up of amount quoted in respect of VAT/ED etc. should be attached in a separate sheet.**
- 4. The agency should have clearly mention the warranty of products quoted by them.**

**Signatures of authorized person**

**Name .....**

**Designation.....**

**Seal**

**FOR PART-5**  
**Annexure-C**  
**Technical Specification**  
**1. DSLR Digital Camera**

Type of Camera	Single-lens reflex digital camera
Effective Pixels	16.2 million
Image Sensor	Nikon DX format (23.6 x 15.6 mm) CMOS sensor
Image Size (Pixels)	4,928 x 3,264 [L], 3,696 x 2,448 [M], 2,464 x 1,632 [S]; D-movie:1920 x 1080 / 24p, 1280 x 720 / 30fps, 1280 x 720 / 25fps, 1280 x 720 / 24fps, 640 x 424 / 24fps
Sensitivity	ISO 100 to 6400 in steps of 1/3, 1/2, or 1 EV, plus HI-0.3, HI-0.5, HI-0.7, HI-1, HI-2 (ISO 25600)
File Format	NEF (12 or 14-bit lossless compressed or compressed RAW), JPEG (Baseline-compliant); MOV movie (H.264/MPEG-4 AVC compression format with Linear PCM sound; Stereo sound with external microphone)
Storage Media	SD memory card (SDHC and SDXC compliant)
Shooting Modes	1) Single frame shooting [S] mode, 2) Continuous low shooting [CL] mode: 1-5 fps, 3) Continuous high shooting [CH] mode: 6 fps, 4) Quiet shutter-release[Q], 5) Self-timer mode, 6)Remote Control 7) Mirror-up mode
White Balance	Auto (TTL white-balance with main image sensor and 2016-pixel RGB sensor), Incandescent, Fluorescent, Direct Sunlight, Flash, Cloudy, Shade, preset manua, choose color temperature
LCD Monitor	3.0", 921,000-dot, low-temperature polysilicon TFT LCD, allows up to 170-degree viewing angle, 100% frame coverage, and brightness adjustment
Playback Function	1) Full-frame, 2) Movie Playback, 3) Thumbnail (4/9/72, calendar) playback, 4) playback zoom, 5) Faces detected during zoom, 6)Slide show 7)Histogram display 8)Highlights, 9) Auto image rotation, 10) Image comment
Delete Function	Single image, Selected images, images taken on a selected date, All images (except protected images)
Interface	USB 2.0 (High-speed), Video output, HDMI output (Type C mini-pin connector),Accessory terminal, Stereo mini-pin audio input
Picture Angle (in 35mm [135] format equivalent)	Approx. 1.5x lens focal length
Viewfinder	Fixed eye-level pentaprism; built-in diopter adjustment (-3 to +1.0 m <sup>-1</sup> )
Focusing Screen	Type B BriteView Clear Matte Mark II screen with AF area brackets
Viewfinder Frame Coverage/Magnification (with 50mm lens at infinity; -1.0 m <sup>-1</sup> )	Approx. 100%/ Approx. 0.94x
Autofocus	TTL phase detection, 39 focus points (9 cross-sensors) by Nikon Multi-CAM 4800DX autofocus module; Detection range: -1 to +19 EV (ISO 100 at 20°C/68°F)
Focus Modes	1) Autofocus (AF): Single-servo AF (AF-S); Continuous servo AF (AF-C); Auto AF-S/AF-C selection (AF-A), predictive focus tracking activated automatically according to subject status 2) Manual focus (MF): Electronic rangefinder can be used
Exposure Metering System	1) 3D color matrix metering II (type G and D lenses), color matrix metering II (other CPU lenses), 2) Center-weighted (weight of 75% given to 8-mm circle in center of frame), 3) Spot metering (meters 3.5-mm circle centered on selected focus point)
Exposure Control	1) Digital Vari-Program (Auto, Auto [Flash Off], 2) Scene ( portrait; landscape; child; sports; close up; night portrait; night landscape; party/indoor; each/snow; sunset ; dusk/dawn; pet portrait; candlelight; blossom; autumn colors; food;

	silhouette; high key; low key); , 3) Programmed Auto [P], 4) Shutter-Priority Auto [S], 5) Aperture Priority Auto [A], 6) Manual [M], 7) U1 (user settings 1) ,8) U2 (user settings 2)
Auto Exposure Bracketing	2 to 3 exposures in increments of 0.3, 0.7, 1.0, 1.3, 1.7, or 2.0 steps to (+-) 2.0 EV
Shutter	Electronically controlled vertical-travel focal plane shutter; 30 to 1/8000sec in steps of 1/3, 1/2 or 1 EV plus bulb time(with ML-L3) and X250
Sync Contact	X-contact only; flash synchronization at up to 1/250 sec
Flash Control	1) TTL: i-TTL balanced fill-flash and standard i-TTL flash for digital SLR using 2,016-pixel RGB sensor are available with built-in flash and SB-900, SB-800,SB-700, SB-600, or SB-400, 2) Auto aperture: Available with SB-900 or SB-800 and CPU lens, 3) Non-TTL auto: Supported flash units include SB-900, SB-800, SB-28, SB-27, and SB-22S, 4) Distance-priority manual: Available with SB-900, SB-800 and SB-700
Flash Sync Modes	1) Front-curtain sync, 2) Red-eye reduction, 3) Slow sync with red-eye reduction, 4) Slow sync, 5) rear-curtain sync
Self-Timer	Electronically controlled timer with duration of 2 s, 5 s, 10 s, 20 s; 1–9 exposures at intervals of 0.5, 1, 2, or 3 s
Depth of Field Preview Button	Yes
Remote Control	Via Wireless Remote Control ML-L3 (optional)
GPS	via GP-1 GPS Unit (optional)
Supported Languages	Total of 22 languages: Arabic, Chinese (Simplified and Traditional), Czech, Danish, Dutch, English, Finnish, French, German, Indonesian, Italian, Japanese, Korean, Norwegian, Polish, Portuguese, Russian, Spanish, Swedish, Thai, Turkish
Power Requirements	Rechargeable EN-EL15 Li-ion battery, EH-5a AC adapter (available separately; requires optional EP-5A power connector )
Battery Life (on a fully charged battery)	Approx 1,050 shots
Tripod Socket	1/4 in. (ISO1222)
Dimensions	Approx. 132 × 105 × 77 mm
Weight (without battery, memory card or body cap)	Approx. 690g
Supplied Accessories (may differ by country or area)	Rechargeable Li-ion battery EN-EL15, Quick charger MH-25, Rubber Eyecup DK-21, Camera strap AN-DC1,Body cap BF-1B, Eyepiece cap DK-5, Accessory shoe cover BS-1, USB Cable UC-E4, Video Cable EG-D2, View NX 2 CD
Other Features	Expeed 2 Image Processing Engine, D-Movie (Full HD recording; external stereo microphone input; in-camera movie editing), Full-time servo AF (AF-F) movie recording, Dual card slots for SD memory cards

## 2. Flash SB5000

Electronic construction	Automatic Insulated Gate Bipolar Transistor (IGBT) and series circuitry
Guide number (at35 mm zoom head position, in FX format, standard illumination pattern)	34.5/113 (ISO 100, m/ft)
Effective flash output distance range (in i-TTL, auto aperture flash or non-TTL auto flash mode)	0.6 to 20 m (2 to 65.6 ft) (varies depending on camera's image area setting, illumination pattern, ISO sensitivity, zoom head position, and lens aperture in use)

Illumination pattern	There are three illumination patterns: standard, even, center-weighted The light distribution angle is automatically adjusted to the camera's image area in both FX and DX formats
Flash mode	i-TTL, Auto aperture flash, Non-TTL auto flash, Distance-priority manual flash, Manual flash, Repeating flash
Other available functions	Test firing, monitor pre-flashes, AF-assist illumination for multi-point AF and modeling illumination
Nikon Creative Lighting System (CLS)	A number of flash operations are available with compatible cameras: i-TTL mode, Advanced Wireless Lighting, modeling illumination, FV lock, Flash Color Information Communication, auto FP high-speed sync, AF-assist illumination for multi-point AF and unified flash control
Multiple flash-unit photography operation	Advanced Wireless Lighting Direct remote wireless multiple flash-unit photography (remote mode)
Bounce capability	Flash head tilts down to 7° or up to 90° with click-stops at -7°, 0°, 45°, 60°, 75°, 90° Flash head rotates horizontally 180° to the left and right with click-stops at 0°, 30°, 60°, 75°, 90°, 120°, 150°, 180°
Power ON/OFF	Rotate the power switch to turn the SB-5000 on or off Standby function can also be set
Power source	Use four AA-size batteries of the same brand from any of the following types:  1.5 V LR6 (AA-size) alkaline batteries 1.2 V HR6 (AA-size) rechargeable Ni-MH batteries
Flash-ready indicator	For minimum number of flashes, recycling time and duration of continuous LED light emission for each battery type, see the user's manual. The SB-5000 is fully recycled: lights up Insufficient flash output for correct exposure (in i-TTL, auto aperture flash, non-TTL auto flash or distance priority manual flash mode, or AUTO mode in direct remote wireless multiple flash-unit photography): flashes slowly
AF-assist illuminator (in remote mode)	The SB-5000 is fully recycled: flashes slowly and goes out Insufficient flash output for correct exposure (in i-TTL, auto aperture flash or non-TTL auto flash mode, or AUTO mode in direct remote wireless multiple flash-unit photography): flashes slowly
Flash duration	Approx. 1/980 sec. at full output
Mounting foot lock lever	Provides secure attachment of the SB-5000 to camera's accessory shoe using locking plate and locking pin to prevent unintentional detachment
Flash exposure compensation	-3.0 EV to +3.0 EV in increments of 1/3 EV steps in i-TTL, auto aperture flash, non-TTL auto flash or distance-priority manual flash mode
Menu settings	24 items
Other functions	ISO sensitivity manual setting, redisplay of amount of underexposure due to insufficient flash output in i-TTL mode, reset to the default settings, key lock, thermal cut-out, firmware update
Dimensions (W x H x D)	Approx. 73 x 137 x 103.5 mm (2.9 x 5.4 x 4.1 in.)
Weight	Approx. 520 g (18.4 oz) (with 1.5 V LR6 (AA-size) alkaline batteries x 4) Approx. 420 g (14.9 oz) (Speed light only)
Included accessories	Speed light Stand AS-22, Nikon Diffusion Dome SW-15H, Fluorescent Filter SZ-4FL, Incandescent Filter SZ-4TN, Soft Case SS-5000, Accessory pouch



### 3. Lens

Camera Setting	Focus			Exposure Mode		Metering System		
<i>Lens/accessory</i>	SC	M (with electronic finder)	M	P, S	A,M	3D Matrix	Color	Center- weighted Spot
Type G or D AF Nikkor <sup>2</sup> AF-S, AF-I Nikkor	Yes	Yes	Yes	Yes	Yes	Yes	-	Yes <sup>3</sup>
PC-E NIKKOR series	-	Yes <sup>4</sup>	Yes	Yes <sup>4</sup>	Yes <sup>4</sup>	Yes <sup>4</sup>	-	Yes <sup>3,4</sup>
PC Micro 85mm f/2.8D <sup>5</sup>	-	Yes <sup>4</sup>	Yes	-	Yes <sup>6</sup>	Yes	-	Yes <sup>3,4</sup>
AF-S / AF-I Teleconverter <sup>7</sup>	Yes <sup>8</sup>	Yes <sup>8</sup>	Yes	Yes	Yes	Yes	-	Yes <sup>3</sup>
Other AF Nikkor (Except lenses for F3AF)	Yes <sup>9</sup>	Yes <sup>9</sup>	Yes	Yes	Yes		Yes	Yes <sup>3</sup>
AI-P Nikkor	-	Yes <sup>10</sup>	Yes	Yes	Yes	-	Yes	Yes <sup>3</sup>